

HYDRAULIC VALVES FOR HYDRAULIC MOTORS

INDEX

➤ OVERCENTER VALVES	VALVES-01
• VALVE TYPE VAKR	VALVES-02
• VALVE TYPE VAKS	VALVES-03
• VALVE TYPE VAKT	VALVES-04
➤ SWITCH VALVES	VALVES-05
• VALVE TYPE VAAR1	VALVES-05
• VALVE TYPE VAAS1	VALVES-05
➤ CROSSOVER RELIEF VALVES	VALVES-06
• VALVE TYPE VABR	VALVES-07
• VALVE TYPE VABS	VALVES-08
• VALVE TYPE VABT	VALVES-09

VALVES FOR HYDRAULIC MOTORS

OVERCENTER VALVES WITH BRAKE CONTROL

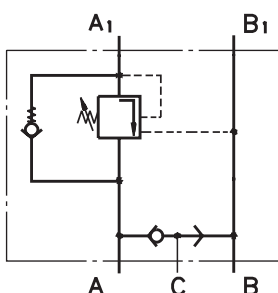

Single Overcenter Valves with Brake Control

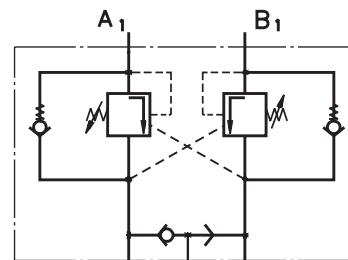

Dual Overcenter Valves with Brake Control

CONTENTS

- Valves for OP and OR type VAKR ... Valves-02
- Valves for OS type VAKS Valves-03
- Valves for OT type VAKT Valves-04
- Switch valves type VAAR1 and VAAS1. Valves-05
- Order Code Valves-10

SPECIFICATION DATA

Parameters	Type					
	VAKR1	VAKS1	VAKR2	VAKS2	VAKT1	VAKT2
Flow Rate, l/min	60				100	
Rated Pressure, bar	250				250	
Pilot Ratio	4,25:1				4,25:1	
Weight, kg	3,300	3,340	3,350	3,390	5,400	5,800

PRESSURE LOSSES

VAKR1(2) and VAKS1(2)

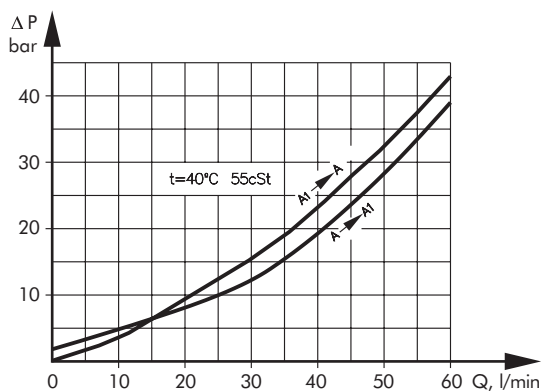

VAKT1(2)

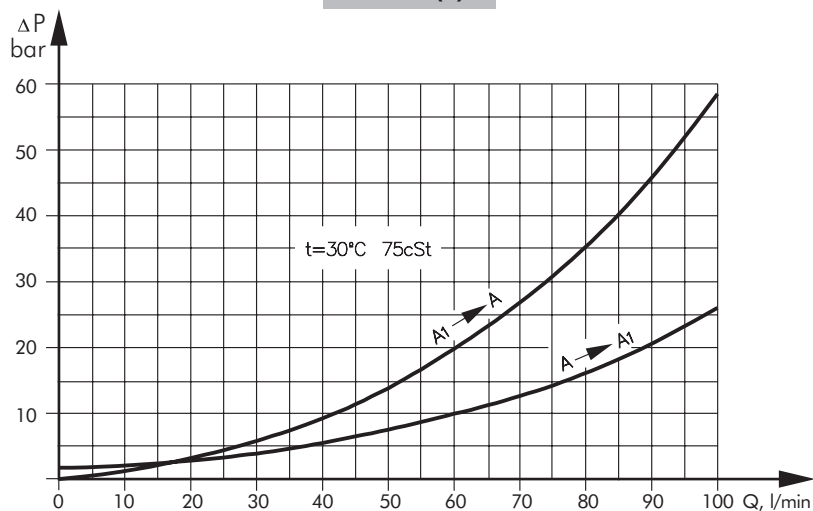

VALVES FOR OS HYDRAULIC MOTORS

SINGLE VALVE VAKS1 ... - Series 2

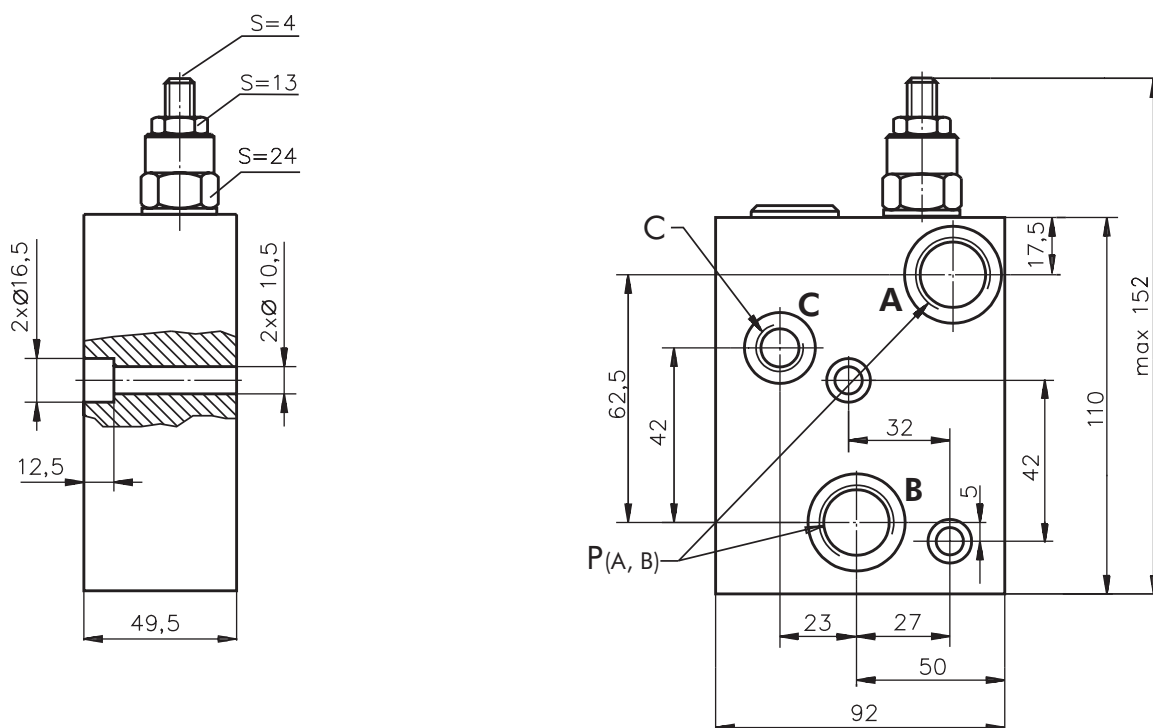

P_(A,B) : G1/2 (M22x1,5), 17 mm depth
C : G1/4 (M14x1,5), 14 mm depth

DUAL VALVE VAKS2... - Series 2

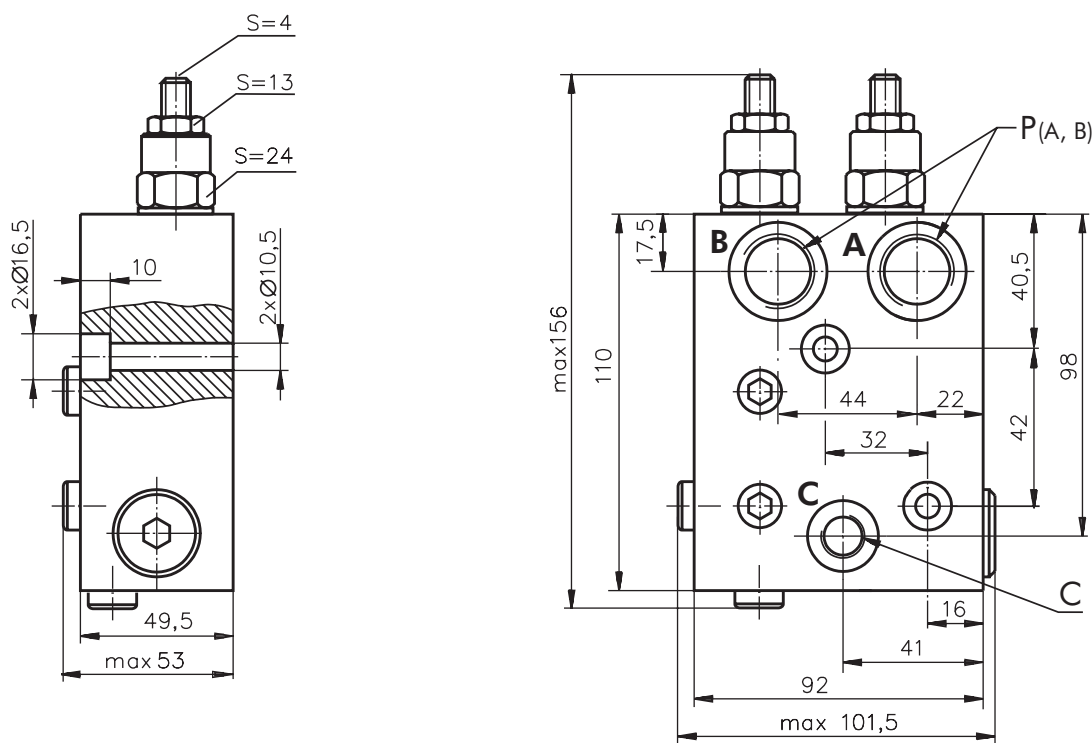

P_(A,B) : G1/2 (M22x1,5), 17 mm depth
C : G1/4 (M14x1,5), 14 mm depth

Note : VAKS Blocks are installed directly on OS Motors with two bolts M10x50 - 8.8 DIN 912.
 Tightening torque $4,5^{+0,5}$ daNm.

VALVES FOR OT HYDRAULIC MOTORS

SINGLE VALVE VAKT1 ...

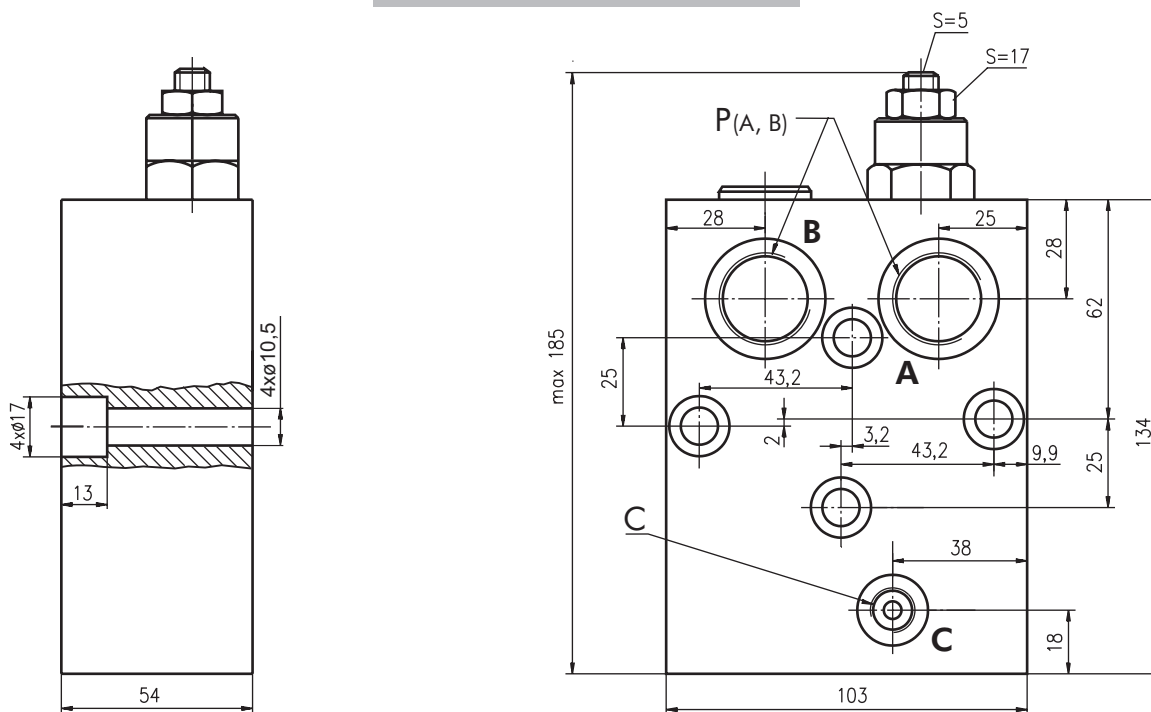

P_(A, B) : G3/4 (M27x2), 17 mm depth
C : G1/4 (M14x1,5), 14 mm depth

DUAL VALVE VAKT2 ...

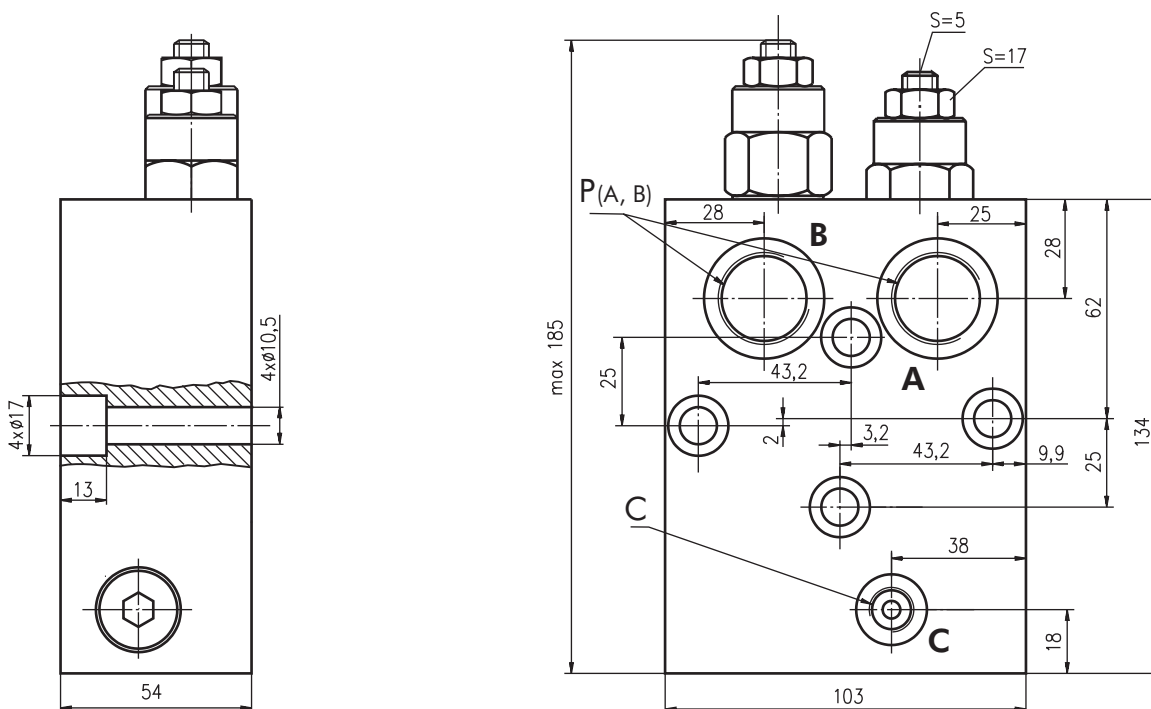

P_(A, B) : G3/4 (M27x2), 17 mm depth
C : G1/4 (M14x1,5), 14 mm depth

Note :VAKT Blocks are installed directly on OT Motors with four bolts M10x55 - 8.8 DIN 912.
 Tightening torque $4,5^{+0,5}$ daNm.



SWITCH VALVES

SPECIFICATION DATA

Parameters	Type	
	VAAR1	VAAS1
Flow Rate, l/min	60	
Rated Pressure, bar	250	
Weight, kg	0,850	0,670

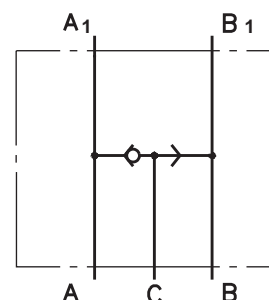

VALVE FOR OP, OR HYDRAULIC MOTORS VAAR1-250

VALVE FOR OS HYDRAULIC MOTORS VAAS1-250

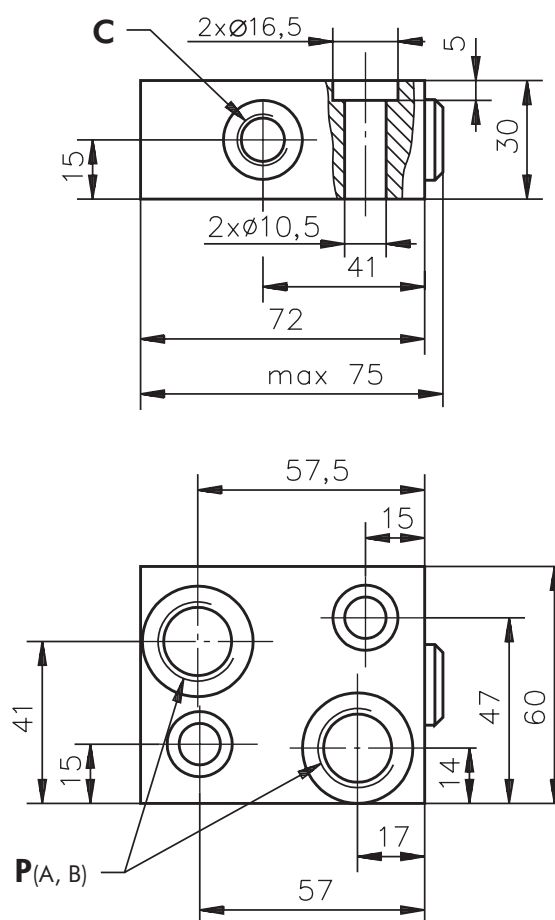
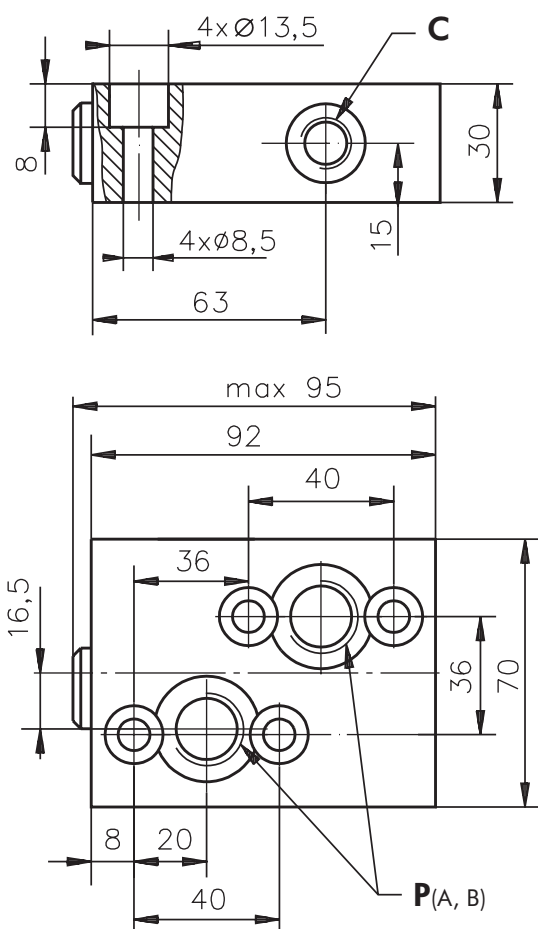

$P_{(A, B)}$: G1/2 (M22x1,5), 17 mm depth
C : G1/4 (M14x1,5), 14 mm depth

Note : VAAR1 Blocks are installed directly on OP and OR Motors with four bolts M8x40 - 8.8 DIN 912. Tightening torque $2^{+0.5}$ daNm.
 VAAS1 Blocks are installed directly on OS Motors with two bolts M10x40 - 8.8 DIN 912. Tightening torque $4,5^{+0.5}$ daNm.

CROSSOVER RELIEF VALVES

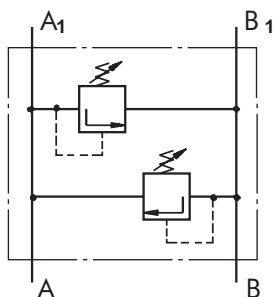

Dual Crossover
Relief Valve

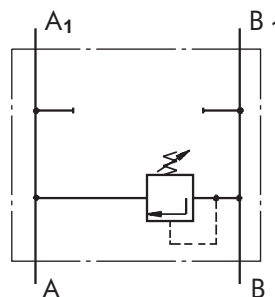

Single Crossover
Relief Valve

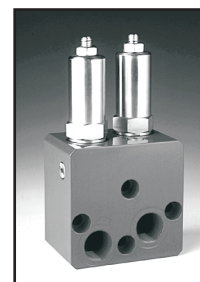

CONTENTS

- Valves for OP and OR type VABR1(2) Valves-07
- Valves for OS type VABS1(2) Valves-08
- Valves for OT type VABT1(2) Valves-09
- Order code..... Valves-10

SPECIFICATION DATA

Parameters	Type					
	VABR1(X)	VABS1(X)	VABR2(X)	VABS2(X)	VABT1	VABT2
Flow Rate, l/min	60				120	
Rated Pressure, bar	30 to 100; 80 to 210				80 to 210	
Weight, kg	1,32	1,58	1,44	1,70	5,10	5,54

Rated Pressure 30÷100 bar

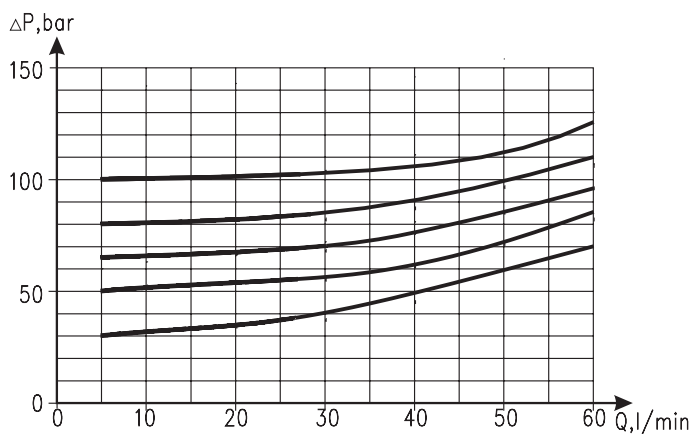

Rated Pressure 80÷210 bar

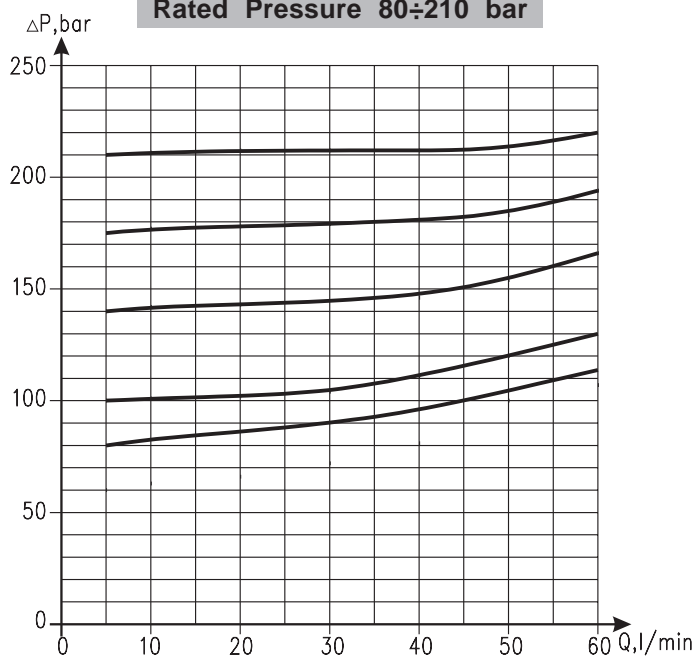

VALVES FOR OP, OR HYDRAULIC MOTORS

DUAL VALVE VABR2

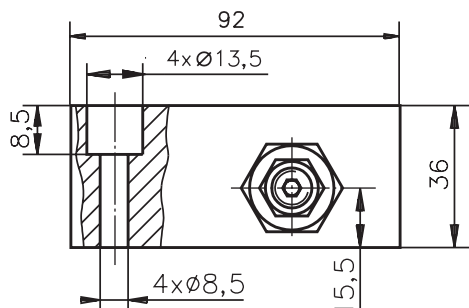

DUAL VALVE VABR2X

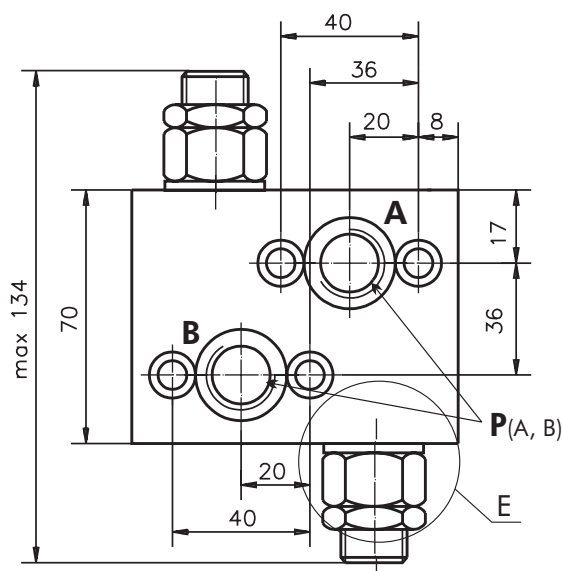
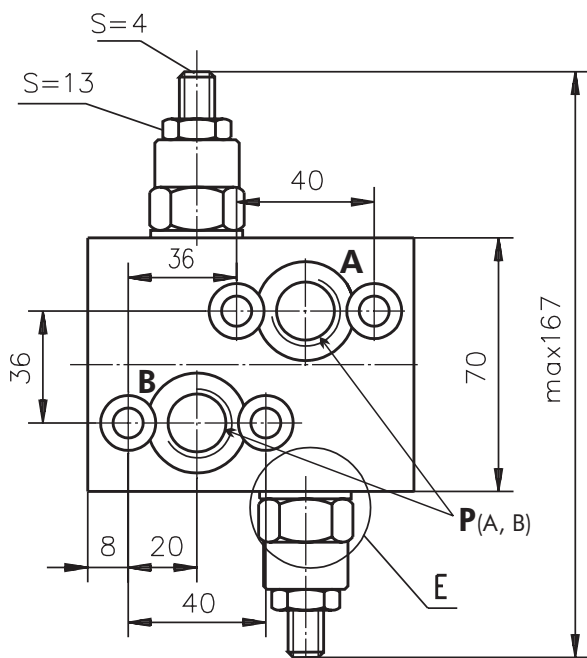
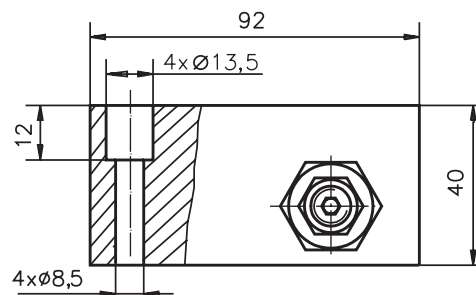

SINGLE VALVES VABR1

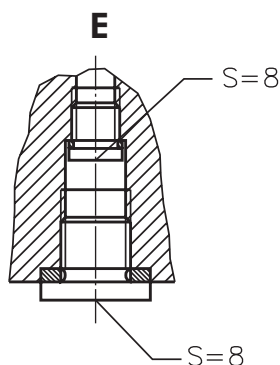

SINGLE VALVES VABR1X

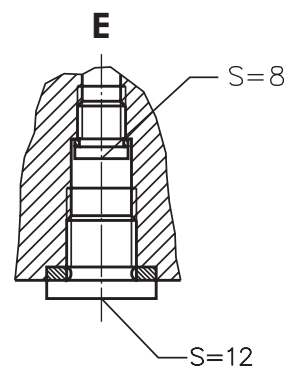

$P_{(A, B)}$: G1/2 (M22x1,5), 15 mm depth

$P_{(A, B)}$: G1/2 (M22x1,5), 17 mm depth

Note:-VABR2(X) (VABR1(X)) Blocks are installed directly on OP and OR Motors with four bolts M8x40-8.8 DIN 912. Tightening torque $2^{+0.5}$ daNm.

VALVES FOR OS HYDRAULIC MOTORS

DUAL VALVE VABS2

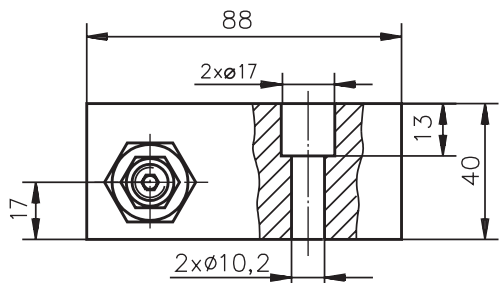

DUAL VALVE VABS2X

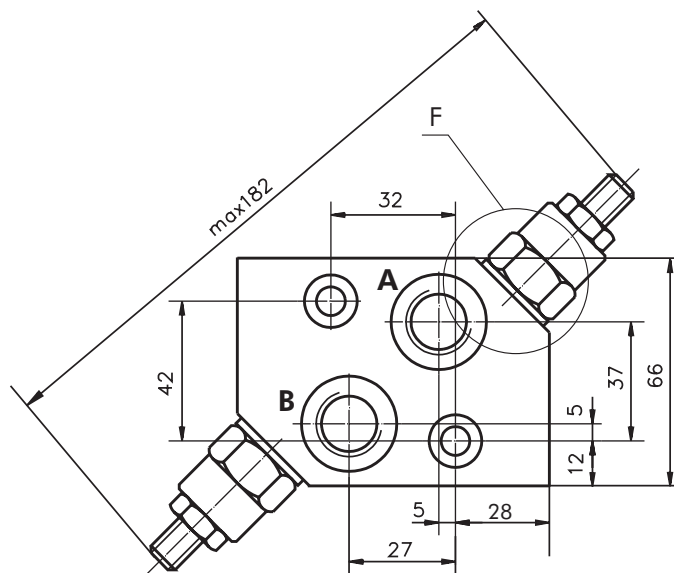
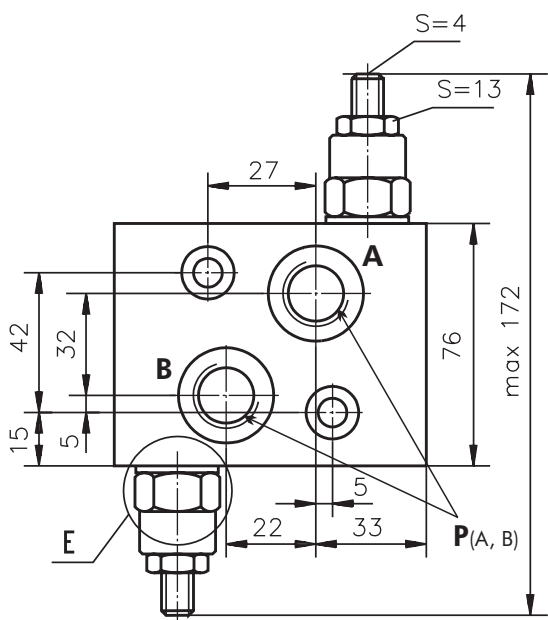
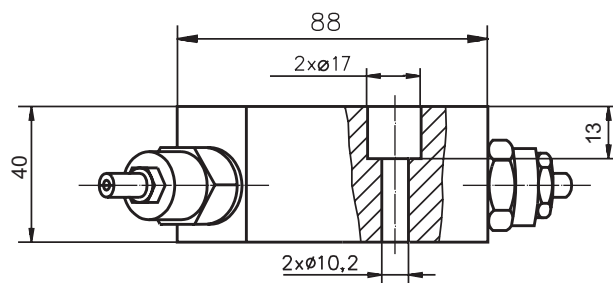

SINGLE VALVES VABS1

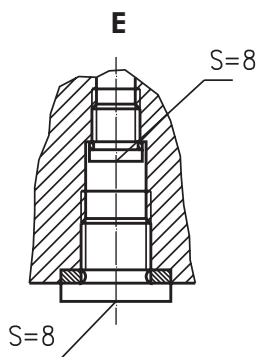

SINGLE VALVES VABS1X

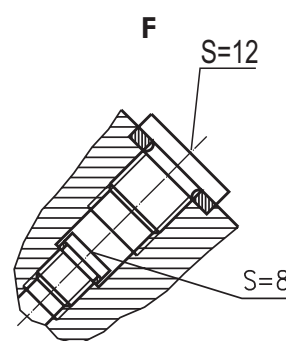

$P_{(A,B)}$: G1/2 (M22x1,5), 15 mm depth

$P_{(A,B)}$: G1/2 (M22x1,5), 17 mm depth

Note:-VABS2(X) (VABS1(X)) Blocks are installed directly on OS Motors with two bolts M10x40-8.8 DIN 912. Tightening torque $4,5^{+0,5}$ daNm.

ORDER CODE - OVERCENTER VALVES WITH BRAKE CONTROL

	1	2	3	4	5	6	7	8
V A			-	/	/			

Pos.1 - Valve Type

- K** - with overcenter valve (s)
- A** - Switch valve

Pos.2 - Housing Type

- R** - Valve block for OP and OR Motors
- S** - Valve block for OS Motors
- T*** - Valve block for OT Motors

Pos.3 - Rated Pressure, bar

250

Pos.4 - Pilot Ratio*

1 -4,25 : 1

Pos.5 - Number of Valves*

- 2** -Two Valves
- 1** -One Valve

Pos.6 - Ports

- omit - BSPP (ISO 228)
- M** - Metric (ISO 262)

Pos.7 - Option (Paint)**

- omit - no Paint
- P** - Painted
- PC** - Corrosion Protected Paint

Pos.8 - Design Series

- omit - Factory specified

NOTES:

- * Useful for K overcenter valve type only.
- ** The color is by customer's request.

ORDER CODE - CROSSOVER RELIEF VALVES

	1	2	3	4	5	6	7
V A					/		

Pos.1 - Number of Valves

- 2** - Two Valves
- 1** - One Valves

Pos.2 - Housing Type

- R** - Valve block for OP and OR Motors
- S** - Valve block for OS Motors
- T** - Valve block for OT Motors

Pos.3 - Housing Design code

- omit - Model 1
- H*** - Model 2

Pos.4 - Max. pressure range, bar

- 100** - 30÷100 [bar]
- 210** - 80÷210 [bar]

Pos.5 - Ports

- omit - BSPP (ISO 228)
- M** - Metric (ISO 262)

Pos.6 - Option (Paint)**

- omit - no Paint
- P** - Painted
- PC** - Corrosion Protected Paint

Pos.7 - Design Series

- omit - Factory specified

NOTES:

- * Useful for types R and S only.
- ** The color is by customer's request.

The Valve Blocks are mangano-phosphatized as standard.
 Many thanks to the production company M+S for the use of Technical Drawing